

# Minetruck MT66 S eDrive

Underground diesel-electric mine truck with  
66-tonne load capacity



# Power to move mountains

The Minetruck MT66 S eDrive combines the cost-effectiveness of a diesel truck with the productivity of an electric one. Equipped with a groundbreaking electric drivetrain, this powerhouse is stronger, faster, and more efficient than any of its precursors. Simply put, it's the best of two worlds.

66 tonnes hauling capacity

SAHR brakes at all wheel ends

## + Main benefits

**Productivity.** The new electric drivetrain and optimized frame design are at the core of the next-generation underground mine trucks. With a 15% boost in productivity, thanks to higher speed and increased payload capacity, this mine truck has the power to move mountains

**Safety.** The Minetruck MT66 S eDrive is designed with safety in mind. Equipped with many smart features, such as automatic brake testing, hill descent assist, and hill-hold function, among others, this underground mine truck ensures the safety of both the operator and the operation

**Reliability** - Equipped with electrical motors, the Minetruck MT66 S eDrive comes with increased availability and utilization rates thanks to a new design philosophy



Minetruck MT66 S eDrive is ready for automation. When automated, this mine truck increases productivity by consistent and predictable tramming cycles. These can be extended into the time between the shifts.



The robust dump box has a load capacity of 66 metric tonnes and the load-weighting system monitors the loading process.



The new electric drive in combination with high ramp speed makes the Minetruck MT66 S eDrive a powerhouse for your underground operations.



Comfortable ROPS and FOPS certified operator's cabin with low noise level and status light

Steer-by-wire and break-by-wire

Cameras for improved visibility

Electric wheel motors

Front axle suspension

Cabin electrics, air filters, jump start connector and batteries easy to reach

## Part of the Smart series

Our Minetruck MT66 S eDrive underground truck is part of the Smart series (S). Equipped with Rig Control System (RCS) and ready for smart functionality such as automation and remote control.

# Minetruck MT66 S eDrive is built from the bedrock

The Minetruck MT66 S eDrive has been completely redesigned to feature an electric drivetrain, powered by the strongest engine yet in Epiroc's line-up of underground mine trucks. With several other upgrades, such as weight reduction of the frame allowing for an additional tonne in the box, and better utilization of the engine's sweet spot, the truck can reach up to 11% higher ramp speed compared to current models.



## + Keep on trucking

The Minetruck MT66 S eDrive offers comfort and ease of operation. Its excellent steering response as a result of the steer-by-wire and brake-by-wire functionality, front-axle suspension, ergonomic operator environment with low noise levels, and one-pedal drive system make it enjoyable to operate for extended periods.



## + Smart hauling

The Minetruck MT66 S eDrive features integrated smart functionality and is automation-ready. It monitors your operation using our telematics solution, Fleet+, which collects and visualizes vital equipment data, enabling you to fully optimize your underground operations.



## + A continuous trucking experience

The new Minetruck MT66 S eDrive is defined by a fresh design philosophy and a completely new machine built from the ground up. By replacing the mechanical drivetrain with an electric drive, this mine truck benefits from an extended lifecycle, increased availability, and improved utilization rates.



## A comprehensive service offering

Even the best equipment needs to be serviced regularly to make sure it sustains peak performance. An Epiroc service solution offers peace of mind, maximizing availability and performance throughout the lifetime of your equipment. We focus on safety, productivity and reliability.

By combining genuine parts and an Epiroc service from our certified technicians, we safeguard your productivity – wherever you are.

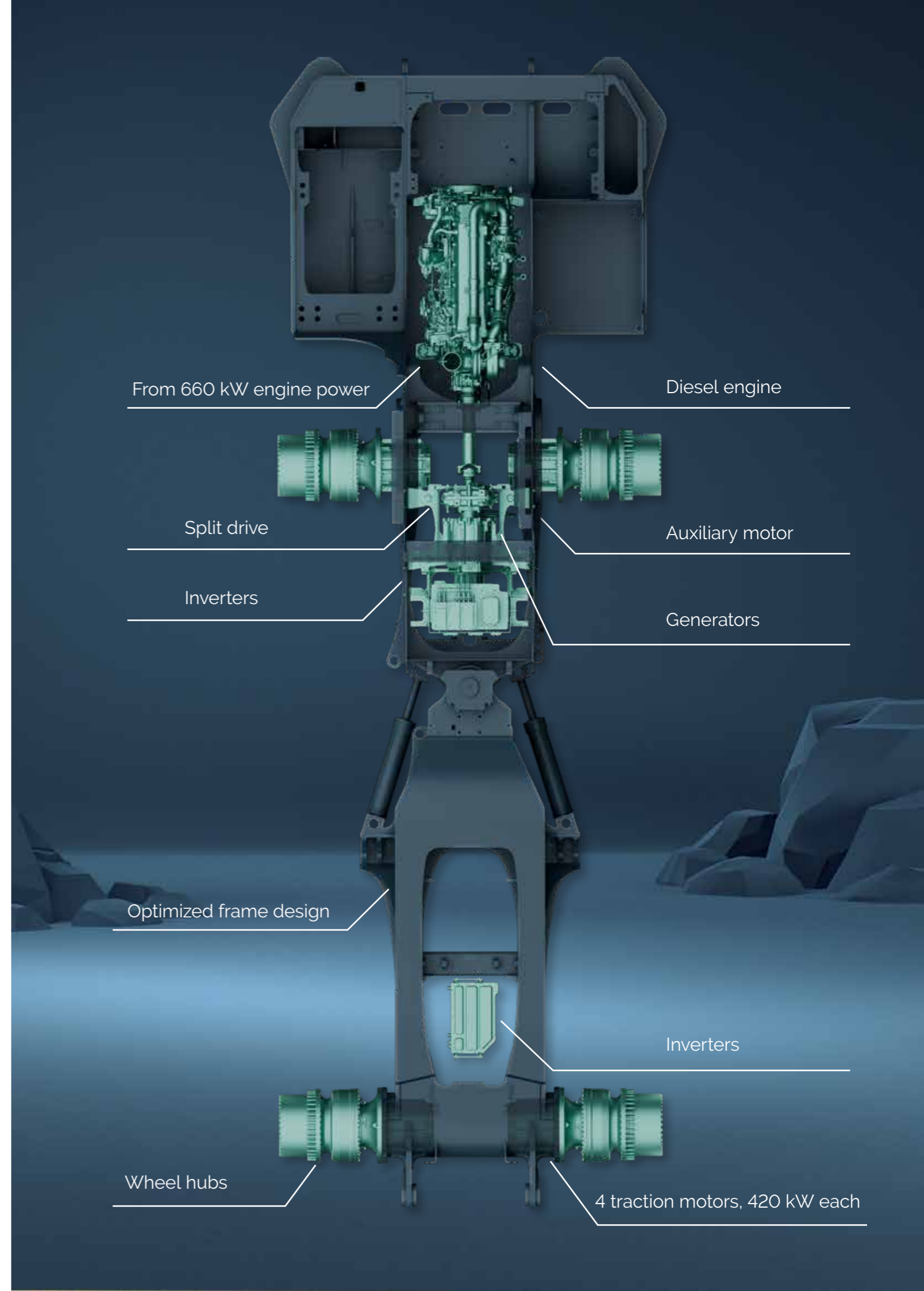

## Technical specifications

### Minetruck MT66 S eDrive

The new Minetruck MT66 S eDrive is the first of Epiroc's large-capacity mine trucks to feature the latest generation electric drivetrain. Along with an upgraded and powerful diesel-engine, the hauler combines the cost-effectiveness of a traditional mine truck with the productivity of an electric one – without requiring change to a mine's infrastructure.

The Minetruck MT66 S eDrive has been completely redesigned to feature an electric drivetrain, powered by the strongest engine yet in Epiroc's line-up of underground mine trucks. With several other upgrades, such as weight reduction and better utilization of the engine's sweet spot, the truck can reach up to 11% higher ramp speed compared to current models



While the Minetruck MT66 S eDrive enables both higher maximum payload and increased speed compared to other high-capacity mine trucks, it also reduces fuel consumption by up to 7% thanks to the electric drivetrain. The removal of mechanical parts also lowers maintenance costs, promising reduced total cost of ownership. All in all, with all these improvements on board, Minetruck MT66 S eDrive offers an easy step to improve productivity quickly.

### Engine

	Standard
Brand/model	John Deere 6180C Stage V
Power rating	660 kW/858 hp @ 1700 rpm
Maximum torque	4 070 Nm @ 1400 rpm
Dry type air cleaner, catalytic exhaust purifier and silencer, remote engine engine oil and cooling fluid drain, cooling package with tube type radiator.	

### Wheel hubs

Brand/model	Kessler R111
-------------	--------------

### Drivetrain

DC link voltage	750 V DC
Generators	2 x 420 kW
Wheel motors	4 x 420 kW
Motor for hydraulic	76 kW

### Fuel

Fuel tank capacity	843 liters
Fuel filtration, primary, including water trap	7 µm
Anti-siphon fuel supply	3 µm

Epiroc underground trucks are compatible with HVO100 fuel

### Requirements and compliances

Machinery directive - 2006/42/EC
Low voltage directive - 2014/35/EC
Electromagnetic compatibility directive - 2014/30/EC

### Specifications

<b>Capacities</b>	
Payload capacity	66 000 kg
<b>Motion times</b>	
Dumping	13 sec
<b>Weights (standard equipped vehicle empty weight)</b>	
Approximate weight	43 000 kg
Axle load, front end	30 300 kg
Axle load, rear end	12 700 kg

\*Weights are approximate and given with filled fluids and standard configured vehicle (e.g. standard equipment, 2.2 t/m<sup>3</sup> dump box etc.)

### Electrical system

System voltage: start and accessories	24 V
Mine duty high output alternator	140 Amps
Converter	24/12 V
Driving lights LED	9x40 W, 2x80 W
Isolation switch lockout	
Main switch isolator	
Tail and brake lights	
Load lights, mounted on back of cabin/canopy	
Side light - opposite operator	
Front and rear turn signals	
Front and rear position lights	
Machine status indicator light mounted on canopy	
3x emergency stop buttons with fuel shut off valve	
Start up alarm	

## Technical specifications

### Control system

Operator display with intuitive interface
Logging of production data, number of dump boxes, fuel consumption and distance, engine and transmission diagnostics etc
Automatic brake test function with logging
Save machine logged data on USB memory stick
Right hand side camera
Rear camera and monitor
Audio-visual reverse alarm
Steering soft stop
Filter supervision
Hill decent assist
Machine speed limit

### Main frame

Lock or support stand on articulation, raised dump box and tilted cabin
Central manual lubrication system
Lifting lugs
Towing points
Removable belly guards
Front-axle oscillating suspension solution with hydraulic suspension cylinders and accumulator cushioning. Maximum travel, 140 mm
Steering soft stop

### Brakes

Separate brake cooling tank, capacity	66 liters
Service/parking/emergency brakes	SAHR
Fully enclosed, force-cooled, multiple wet discs at each wheel end	
Parking brake apply if movement is detected in neutral	
Electric brake release pump	
Retarder, exhaust brake	

### Tires

Tire size front and rear	35/65R33
Tubeless tires design for underground mine service*	
*As applications and conditions vary; Epiroc recommends that the user consults with tire suppliers to obtain the optimum tire selection.	

### Hydraulic system

System pressure	24 MPa
Hydraulic tank capacity	292 liters
Filtration, return line	12 µm
Electric pump for hydraulic tank fill	24 V
Variable speed heavy duty gear pump	

### Operator's compartment

Forward seated cabin with steering wheel (ISO ROPS and FOPS)
Trainer seat with seat belt
Door open brake apply (at low speeds)
Open door retainer
Air suspended seat with 3-point retractable seat belt
Emergency exit (and rescue mission)
Window wipers on front and window facing towards engine
Sliding window on door
Horn
Tilt/telescopic steering wheel
Heated rear view mirrors
External sound level according to ISO 6395 LwA 117 dB(A)
Sound level in cabin according to ISO 6396 LpA 80 dB(A)
Whole body vibration value according to EN 14253 A(8)w maximum 0.65 +/- 0.2m/s <sup>2</sup>



# Technical specifications

## 1. Measurements

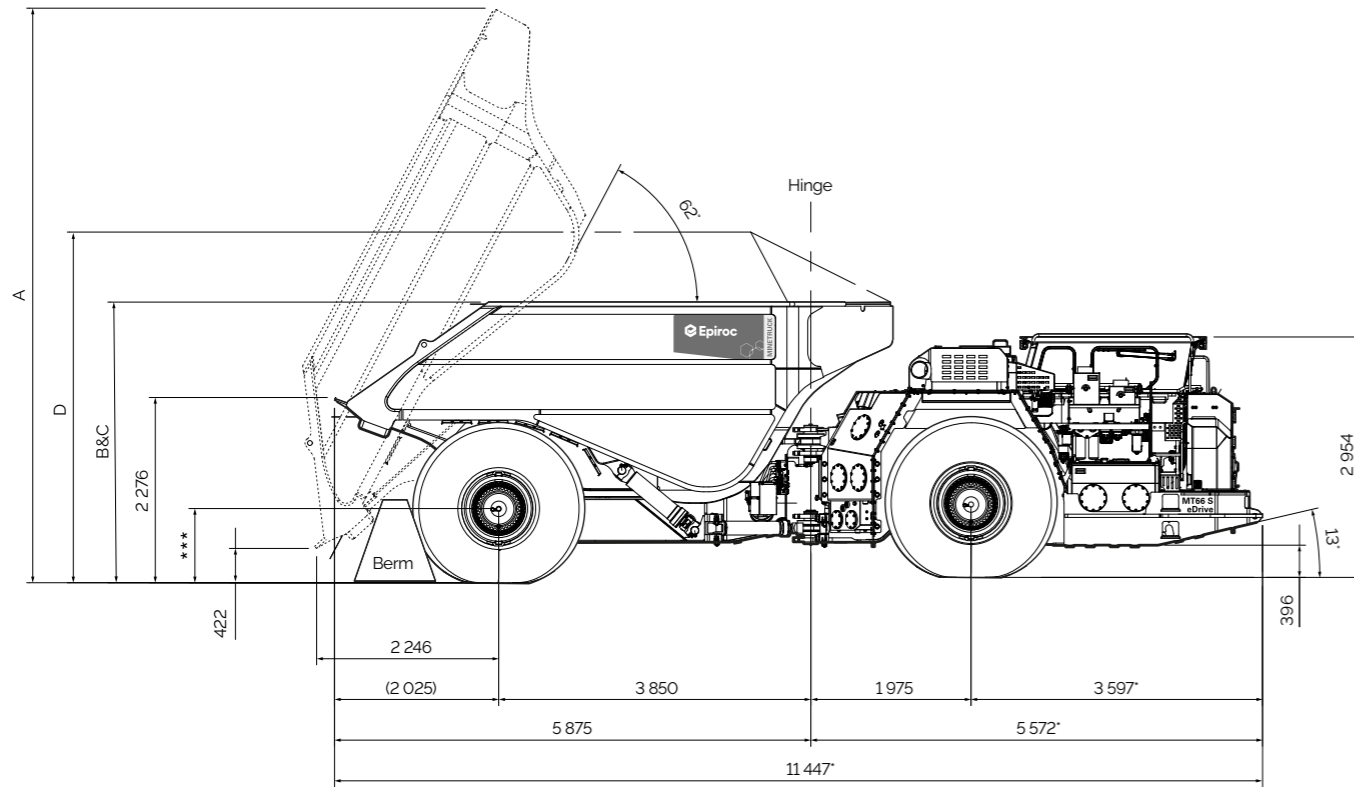

Dimensions are shown in millimetres. Dimensions shown are based on standard vehicle configuration, with 78 mm tire deflection in the front and 36 mm deflection in the rear, unloaded.

\*Refers to dimensions including batwings

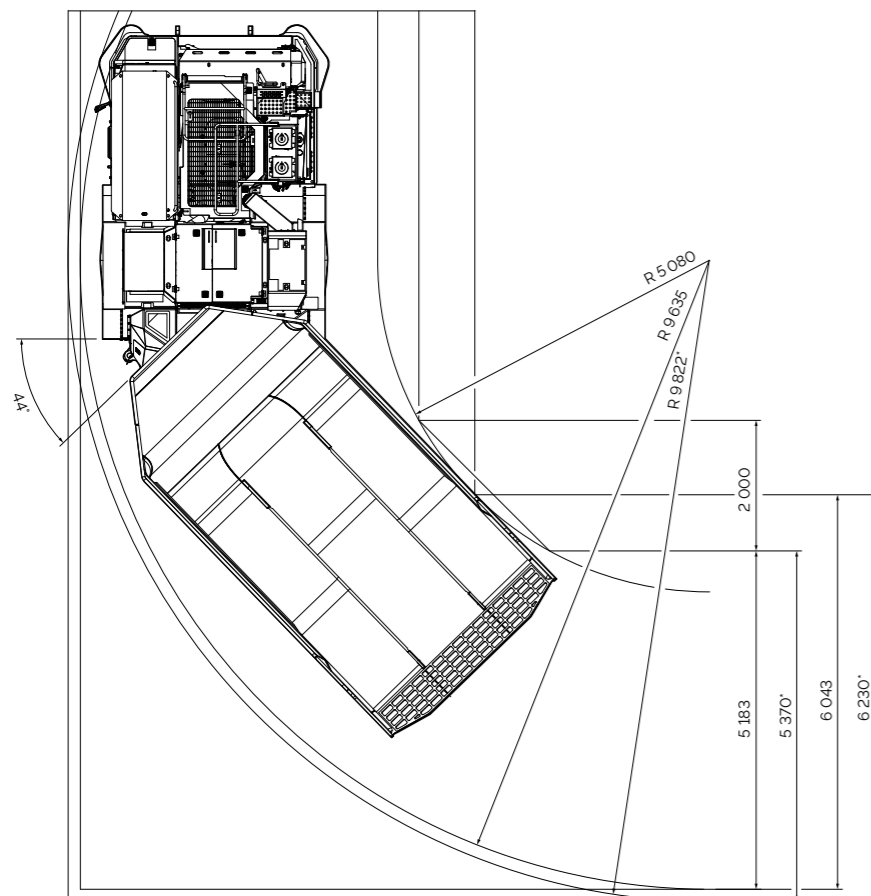

View showing box (1.6t/m<sup>3</sup>)  
\* Refers to dimensions including batwings

# Technical specifications



## Grade performance\*

Standard configuration, box empty												
%	Grade	0.0	2.0	4.0	6.0	8.0	10.0	12.0	14.0	16.0	18.0	20.0
Ratio	Grade	-	-	-	-	1.12	1.10	1.8	1.7	-	-	1.5
Km/h		279	279	279	279	279	279	279	25.5	22.6	20.5	19.8
Standard configuration, box loaded												
%	Grade	0.0	2.0	4.0	6.0	8.0	10.0	12.0	14.0	16.0	18.0	20.0
Ratio	Grade	-	-	-	-	1.12	1.10	1.8	1.7	-	-	1.5
Km/h		279	279	24.5	20.4	17.2	14.1	12.6	11.0	10.0	9.1	8.2

\*These are theoretical calculations and should be seen as a reference only. 3% rolling resistance assumed. Actual performance may vary depending on the application. Continuous operation is recommended on maximum 17 grade.

## Dump boxes

Volume, SAE heaped (m3)	40	
Volume, semi-heaped (m3)	37	
Volume, SAE struck (m3)	34	
Maximum material density (t/m3)	1.63	
Dump position: box height	A (mm)	7132
Height heaped load	D (mm)	4268
Dump box loading height	C (mm)	3514
Height rear end (mm)		2276
Width over dump box (mm)		3500
Width inside dump box (mm)		3306

More dump box sizes and ejector box to come

## Technical specifications

### Options



#### Main frame

Optional box sizes
Wheel chocks and brackets
Central automatic lubrication system (with low level warning)
Guard rails
Corrosion resistant radiator
Ansul manually activated fire suppression system with engine shut down
Ansul checkfire automatically activated fire suppression system
Hand held fire extinguishes
Cold weather package 120 V or 240 V: Block heater, battery charger, fuel heater, hydraulic oil heater, transmission oil heater, arctic oil
Wiggins fast fuel fill
Wiggins fast fill for engine oil, hydraulic and radiator

#### Electrical system

Engine starter isolator
Detachable service light (required for CE approved vehicles)
Battery jump start receptacle
Amber strobe light - power on

#### Parts and Service solutions

Preventive maintenance kits
Parts & Repair kits
Upgrade kits
Midlife kits
Service agreements
Reman components
RigScan audits

#### Control system

Load camera and load lights
Collision avoidance system (CAS) interface
Emergency steering
Load weighing
Tire monitoring system
Machine protection system (engine, hydraulic, lubrication)*
Overspeed protection system*
Machine warm up*
Configurable setting at dump box up*
Operational ID: manage operator, material, haulage points, delay codes etc.*
Turbo timer*
* Local adaptations - explain more

#### Operator's compartment

Air suspended seat with 4-point retractable seat belt
Seat cover
Media player
Sun visor

#### Hydraulic system

Arctic oil
------------

#### Fuel

Diesel filter with heater element
-----------------------------------

#### Digital products

Fleet monitoring with Fleet+ on My Epiroc
Machine and fleet data via APIs

## Related underground loader - Scooptram ST18 S

Combining strength and agility, the Scooptram ST18 S is built for high productivity in large-size underground mines. It offers unbeatable safety feature to secure your operation. At the same time, thanks to the integrated converter lock-up, load sensing hydraulic, traction control and the intelligent Epiroc Rig Control System (RCS), you will enjoy new levels of productivity. With the Scooptram ST18 S the operator can count on a spacious cabin, ergonomic controls, dual ride control and soft stop for steering and boom movements.



#### Engine

Cummins X15 turbo charged diesel engine		
Emmissions standard	EPA Tier 3/ EU Stage IIIA	EPA Tier 4 Final/ EU Stage 5
Power rating at 2 000 rpm	336 kW/450 hp	352 kW/472 hp
Maximum torque at 1 000-1 400 rpm	2 100 Nm	2 350 Nm
MSHA Part 7 ventilation rate	495 m <sup>3</sup> /min	481 m <sup>3</sup> /min
MSHA Part 7 particulate index	481 m <sup>3</sup> /min	14 m <sup>3</sup> /min

**Tier III/EU Stage IIIA:** Dry type air filter, catalytic purifier and silencer, exhaust heat protection, cooling package with tube type radiator, remote engine oil and cooling fuel drain.

**Tier 4 final/EU Stage V:** Different engine, coolers, different after-treatment systems (dry type air filter with cyclone functionality, SCR, DPF, Diesel emission fluid system with separate tank/fill point including dosing pump and hoses/cables).

**Please note!** Requires ultra-low sulfur diesel and low ash engine oil.

#### Specifications

Capacities	
Tramming	17 500 kg
Breakout force, hydraulic	28 500 kg
Breakout force, mechanical	26 000 kg
Weights (Standard empty vehicle)	
Approximate weight	51 500 kg
Axle load, front end	25 000 kg
Axle load, rear end	26 500 kg
Motion times	
Boom raising	7.2 sec
Boom lowering	4.0 sec
Dumping	2.2 sec

# United in performance. Inspired by innovation.

Performance unites us, innovation inspires us, and commitment drives us to keep moving forward. Count on Epiroc to deliver the solutions you need to succeed today and the technology to lead tomorrow.  
**[epiroc.com](https://www.epiroc.com)**

