

# Minetruck MT33

Underground mine truck with 33-tonne load capacity



# Hauling in big style

Minetruck MT33 is a high-capacity 33-tonnes underground truck for medium to large drifts. Built on years of experience and based on the reliable Minetruck MT436, it brings lots of improvements in areas such as safety, productivity, reliability and operator comfort. It combines high ramp speeds with a low profile and robust design to make your operations efficient and dependable - so you can haul in big style.



The integrated load weighing system, connected with Fleet\*, gives operators real-time insights into productivity and performance, facilitating smarter, data-driven decisions underground.



The newly added right-hand side camera, complements the rear view for enhanced visibility. It improves situational awareness underground, helping operators maneuver safely and efficiently in tight spaces.



The upgraded operator cabin features a new air conditioner, air-suspended seat, and intuitive touch-screen display, delivering maximum comfort and control for a smoother underground shift.



## + Main benefits

**Productivity** - The Minetruck MT33 delivers exceptional productivity through its high 33-tonnes capacity, automatic transmission and the newly added PLC display that enhances data accessibility and performance monitoring.

**Safety** - Built with safety in every detail, the Minetruck MT33 offers peace of mind underground. Featuring factory-fitted emergency stops, braking systems, and enhanced visibility through integrated cameras, it is designed to protect operators and keep operations running smoothly, even in the toughest conditions.

**Reliability** - Built to last, the Minetruck MT33 has strategically placed components for maximum protection, reduced wear, and longer life. Its smart PLC display improves serviceability by streamlining diagnostics and maintenance, while features like engine delay shutdown and soft stops ensure an ongoing productivity.

\* Optional equipment

# Keep on trucking in big style with Minetruck MT33

The Minetruck MT33 is engineered to boost productivity while ensuring safe, efficient, and reliable haulage in underground mining and construction operations. Its low weight and impressive 33-tonne payload capacity deliver high output at optimal cycle times.



## + Simple and easy productivity

The Minetruck MT33 is built for high-efficiency underground haulage, combining a powerful 33-tonne payload with automatic transmission for smooth acceleration and optimal cycle times. Paired with Epiroc's 10-tonne underground loader, Scooptram ST1030, it can move up to 330 tonnes per shift, delivering unmatched productivity in medium drifts and demanding conditions.



## + Follow data in real time

The new PLC system in the Minetruck MT33 empowers more efficient decision-making, streamlines diagnostics and reduces downtime thanks to effortless data accessibility. Inspired by Epiroc's Rig Control System, this lite RCS offers intuitive access to real-time data, helping operators monitor productivity, performance, and maintenance needs with ease, turning every shift into a more productive operation.



## + Reliability you can count on

With a robust transmission, sturdy axles, and a newly improved engine, it is engineered to handle heavy loads and harsh underground conditions with ease. The PLC display enhances serviceability by streamlining diagnostics and maintenance, while features like delayed engine shutdown and soft stops extend component life.



## A comprehensive service offering

Even the best equipment needs to be serviced regularly to make sure it sustains peak performance. An Epiroc service solution offers peace of mind, maximizing availability and performance throughout the lifetime of your equipment. We focus on safety, productivity and reliability.

By combining genuine parts and an Epiroc service from our certified technicians, we safeguard your productivity – wherever you are.



## Technical specifications

### Features

The Minetruck MT33 is built to deliver safe, productive, and reliable performance in demanding underground environments.

Advanced safety features like door open brake apply (DOBA), emergency stops, and enhanced visibility through rear and side cameras ensure operators and the entire operation are protected.

With a 33-tonne payload capacity, automatic transmission, and real-time data access via the PLC display, Minetruck MT33 maximizes productivity while maintaining optimal cycle times.

Reliability is reinforced through a robust drivetrain, sturdy axles, and delayed engine shutdown, designed to withstand harsh conditions and extend component life.

Serviceability is streamlined with easy access to filters and diagnostics, reducing downtime and supporting proactive maintenance.

Inside the cabin, operators benefit from improved air conditioning, an air-suspended seat, and a user-friendly touch-screen display, all designed for comfort and ease of operation throughout the shift.



### Engine

Standard	
Brand/model	Cummins QSM11 EPA Tier 3
Power rating	298 kW/400 hp @ 2100 rpm
Maximum torque	1 898 Nm @ 1 350 rpm
MSHA Part 7 ventilation rate	396 m <sup>3</sup> /min
MSHA Part 7 particulate index	311 m <sup>3</sup> /min

**Tier III/EU Stage IIIA:** Dry type air filter, catalytic purifier and silencer, exhaust heat protection, cooling package with tube type radiator, remote engine oil and cooling fuel drain. Cooling package with V core tube type radiator.

### Fuel

Fuel tank capacity	439 litres
Fuel filtration, primary, including water trap	8 µm
Fuel filtration, secondary	3 µm

Epiroc underground trucks are compatible with HVO100 fuel

### Axles

Brand/model	Okubo Rock Tough 508
Oscillation	18° (9° on each side)
Differentials: front	Open
Differentials: rear	Open

### Brakes

Service/parking/emergency brakes	SAHR
Fully enclosed, force-cooled, multiple wet discs at each wheel end	
Engine compression brake	

### Specifications

Capacities	
Tramming capacity	32 650 kg
Motion times	
Dumping	14 sec
Weights (standard equipped vehicle, empty weight)	
Approximate weight	30 600 kg
Axle load, front end	20 500 kg
Axle load, rear end	10 100 kg
Weights (standard equipped vehicle, loaded weight)	
Approximate weight	63 250 kg

### Tires

Tire size front and rear	26.5R25
Tubeless tires design for underground mine service*	
*As applications and conditions vary; Epiroc recommends that the user consults with tire suppliers to obtain the optimum tire selection.	

### Electrical system

System voltage: start and accessories	24 V
Mine duty high output alternator	140 Amps
Converter	24/12 V
Driving lights LED	9x40 W
Isolation switch lockout	
Tail and brake lights	
Side light - opposite operator	

## Technical specifications

### Operator's compartment

Canopy	
Side seated canopy for bi-directional operation with stick steering (ISO ROPS/FOPS)	
Spring suspended seat, with 2 point retractable seat belt	
Cabin (optional)	
Forward seated cabin with steering wheel (ISO ROPS/FOPS)	
Air condition system and pressurizer	
Sliding window on door	
Spring suspended seat, with 2 point retractable seat belt	

### Sound and vibration

Inside canopy or cabin	
Sound pressure level cabin, LpA according to ISO 6396:2008	85 dB
Sound level in canopy according to ISO 6396:2008	108 dB
Whole body vibration value according to EN 14253 A(8) w	range of 0.5 to 2 m/s <sup>2</sup>
External	
Sound power level, LwA according to ISO 6395:2008	123 dB

### Hydraulic system

System pressure	15.8 MPa
Hydraulic tank capacity	238 liters
Filtration, return line	4 µm
Heavy duty gear type pumps	
Manual pump for hydraulic tank fill	
Chrome plated stems on cylinders	

### Transmission

Brand/model	Dana 6 000 series
Converter	Single stage with automatic lock-up
Full power shift, 4 speed forward/reverse	

### Control system

Rear camera and monitor
Audio-visual reverse alarm
Joystick controls for steering and dump control for side seated bi-directional operation
Speedometer

### Main frame

Lock on articulation and raised dump box
Central manual lubrication system
Teletram dump box changes dumping method and vehicle dimensions (consult with your local customer center)



# Technical specifications

## 1. Measurements

Turning radius

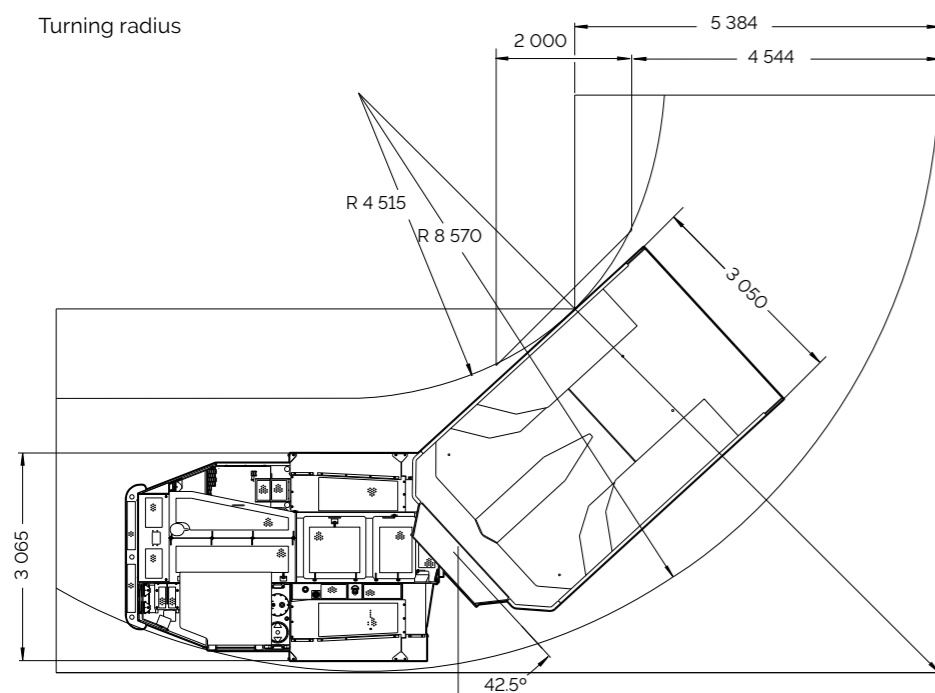

Dimensions  
 Turning angle +/- 42.5°  
 Turning radius left and right are symmetrical  
 Dimensions shown are based on standard vehicle configuration, with loaded box with 25 mm tire deflection  
 All dimensions are shown in millimetres

Side view

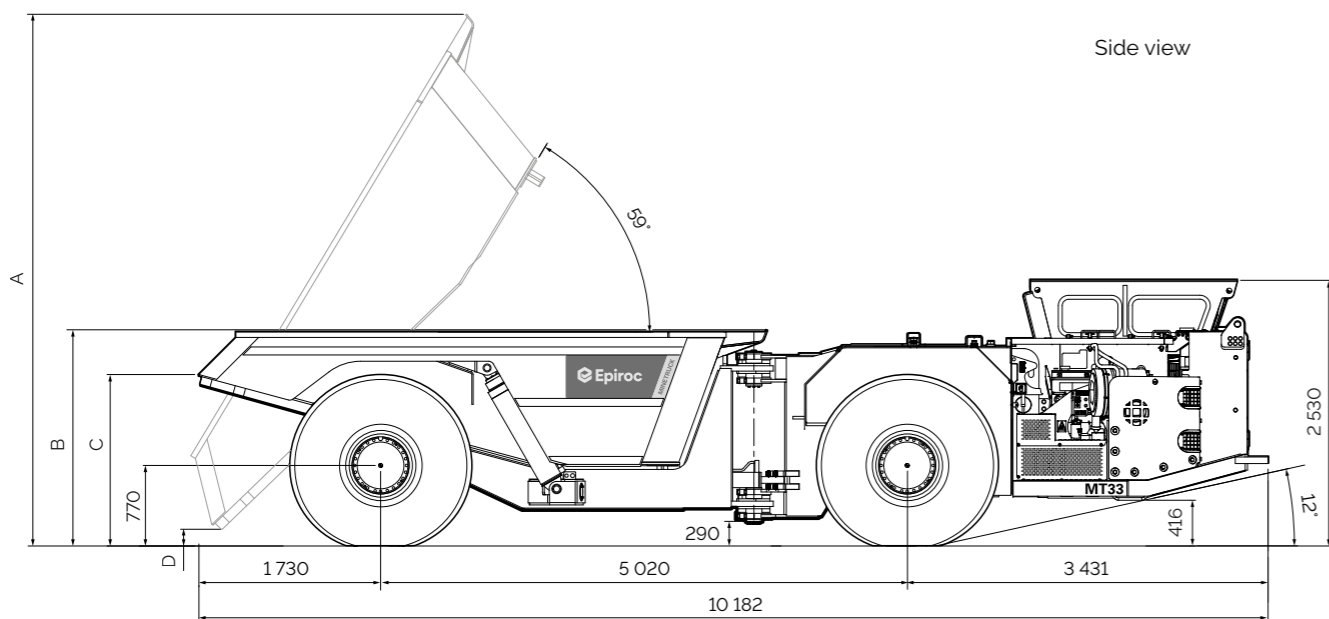

### Dump and teletram boxes

	Dump boxes			STD	Teletram boxes*			
Volume, SAE heaped (m3)	20	18	16	14.5	12.5	21	14.5	
Volume, semi-heaped (m3)	18.25	15.75	14	12.5	10.6	18.75	12.5	
Volume, SAE struck (m3)	16.5	13.5	12	10.5	8.7	16.5	10.5	
Maximum material density (t/m3)	16	18	2	2.2	2.6	11	19	
Dump position: box height, max (mm)	A	5 445	5 310	5 150	5 070	5 045	3 170	2 615
Load position: height side board / (TT push plate) mm	B	2 520	2 360	2 150	2 040	2 010	3 085	2 449
Height rear end / (TT tailgate)	C	1 900	1 900	1 636	1 636	1 636	2 163	2 150
Dump position: clearance (mm)	D	240	240	160	165	160	-	-
Box width		3 050	3 050	3 050	3 050	3 050	3 355	3 205

\*Teletram box has reduced capacity, different dimensions affecting turning radius etc. More sizes can be available, please consult Epiroc for more information.

# Technical specifications



### Grade performance\*

Standard configuration, box empty

%	Grade	0.0	2.0	4.0	6.0	8.0	10.0	12.0	14.0	16.0	18.0	20.0
---	-------	-----	-----	-----	-----	-----	------	------	------	------	------	------

Ratio	Grade	-	-	-	-	1:12	1:10	1:8	1:7	-	-	1:5
-------	-------	---	---	---	---	------	------	-----	-----	---	---	-----

Km/h	1st gear	5.5	5.5	5.5	5.4	5.4	5.4	5.4	5.4	5.4	5.4	5.3
	2nd gear	9.8	9.7	9.7	9.7	9.6	9.6	9.5	9.5	9.4	9.4	9.3
	3rd gear	17.3	17.1	17.0	16.9	16.7	16.6	16.0	14.7	13.4	12.0	-
	4th gear	30.7	30.2	29.8	27.4	23.1	-	-	-	-	-	-

Standard configuration, box loaded

%	Grade	0.0	2.0	4.0	6.0	8.0	10.0	12.0	14.0	16.0	18.0	20.0
---	-------	-----	-----	-----	-----	-----	------	------	------	------	------	------

Ratio	Grade	-	-	-	-	1:12	1:10	1:8	1:7	-	-	1:5
-------	-------	---	---	---	---	------	------	-----	-----	---	---	-----

Km/h	1st gear	5.5	5.4	5.4	5.4	5.3	5.3	5.3	5.3	5.2	5.2	5.0
	2nd gear	9.7	9.6	9.5	9.4	9.4	9.0	8.1	7.2	6.2	-	-
	3rd gear	17.1	16.8	16.3	13.6	-	-	-	-	-	-	-
	4th gear	30.0	24.5	-	-	-	-	-	-	-	-	-

\*These are theoretical calculations and should be seen as a reference only. 3% rolling resistance assumed. Actual performance may vary depending on the application. Continuous operation is recommended on maximum 1:7 grade.



Options

Engine

Brand/model: Cummins X12	EPA Tier 4 final / EU Stage V
Power rating at 2100 rpm	298kW / 400hp
Maximum torque at 1400 RPM	1898 N-m / 1400 lb-ft
MSHA Part 7 ventilation rate	N/A
MSHA Part 7 particulate index	N/A

\*MSHA - Mine Safety and Health Administration, USA. Ventilation rate - quantity of additional ventilation air required to dilute raw exhaust emission to a respective level per engine.  
 \*\*Particulate Index - Calculated air flow for minimum diesel particulate matter (DPM) dilution to a safe level per engine.

Main frame

Optional box sizes and tailgate configuration
Teletram dump box
Wheel chocks and brackets
Central automatic lubrication system
Arctic Oil
Corrosion resistance radiator
Ansul manually activated fire suppression system with engine shut down
Hand held fire extinguishes
Ansul manually activated fire suppression system with engine shut down
Wiggins fast fuel fill
Wiggins fast hydraulic oil fill

Operator's compartment

<b>Canopy</b>
Side seated low built canopy for bi-directional operation with stick steering (ISO ROPS/FOPS)
Spring suspended seat, with 3 point retractable seat belt
Heater
<b>Cabin (optional)</b>
Cyclone filter
Spring suspended seat, with 3 point retractable seat belt
DOBA (door open brake apply)
Heater
Media player

Control system

Emergency steering
Load weighing system

Digital products

Fleet monitoring with Fleet+ on My Epiroc
Machine and fleet data via APIs

Parts and Service solutions

Preventive maintenance kits
Parts & Repair kits
Upgrade kits
Midlife kits
Service agreements

Scooptram ST1030 is a reliable 10-tonne underground loader for mid-sized mining applications. It is designed with an ergonomic operator compartment for unparalleled productivity and safety.



Engine

<b>Cummins L9</b>	
Emissions standard	EPA Tier 4 Final / EU Stage 5
Power rating at 2 000 rpm	213 kW
Maximum torque at 1 500 rpm	1 636 Nm
MSHA Part 7 ventilation rate	283 m³/min
MSHA Part 7 particulate index	28 m³/min

**Tier 4 final/EU Stage V:** Different engine, coolers, different after-treatment systems (dry type air filter with cyclone functionality, SCR, DPF, Diesel emission fluid system with separate tank/fill point including dosing pump and hoses/cables).  
**Please note!** Requires ultra-low sulfur diesel and low ash engine oil.

Specifications

<b>Capacities</b>	
Tramming	10 000 kg
Breakout force, hydraulic	18 810 kg
Breakout force, mechanical	17 600 kg
<b>Weights (Standard empty vehicle)</b>	
Approximate weight	28 900 kg
Axle load, front end	12 700 kg
Axle load, rear end	16 200 kg
<b>Motion times</b>	
Boom raising	8.3 sec
Boom lowering	6.0 sec
Dumping	2.1 sec

# United in performance. Inspired by innovation.

Performance unites us, innovation inspires us, and commitment drives us to keep moving forward. Count on Epiroc to deliver the solutions you need to succeed today and the technology to lead tomorrow.  
**[epiroc.com](https://www.epiroc.com)**

